

4

3

2

1

REV	REVISION RECORD	ECN	BY	APVD	DATE
A	INITIAL DESIGN	506672	KR	KR	07/26/13

NOTES: UNLESS OTHERWISE SPECIFIED

- 1. INTERPRET DRAWING IN ACCORDANCE WITH ASME Y14.5-2009. (1-01)
- 2. ALL DIMENSIONS APPLY AFTER PLATING.
- 3. 0.25 [.010] MAX RADII AND FILLET. (1-02)
- 4. ASSEMBLY DIMENSIONS ARE MEASURED IN A RESTRAINED STATE.
- 5 PARTS SUPPLIED ON A CONTINUOUS REEL AS SHOWN
- 6 HEADER SIZES CUT FROM A REEL ARE PACKAGED IN THERMOFORMED TRAYS.

### PART NUMBER / ORDERING CODE

23-1078 R 00 [ ] [ ]

**TYPE**  
2 ROW 3.50 [.138]  
CENTERS

**FINISH**  
"TT" = 1.02µm [40µ"] MIN  
MATTE Sn (Pb FREE)  
OVER 2.03µm [80µ"] MIN Ni.

**RECT. PIN COMPLIANT**  
0.81 X 1.50  
[.032] [.059]

**DIMENSIONS**

CODE	"Z"
A1	14.55 [.573]

**TOTAL NO. OF POS.**  
00 = CONTINUOUS REEL  
6 CUT HEADER SIZES:  
2 TO 20 POSITIONS BULK  
PACKAGED IN TRAYS

ADDITIONAL PIN SIZES & LENGTHS UP TO  
"Z" = 40 [1.575] CAN BE MADE UPON  
REQUEST.

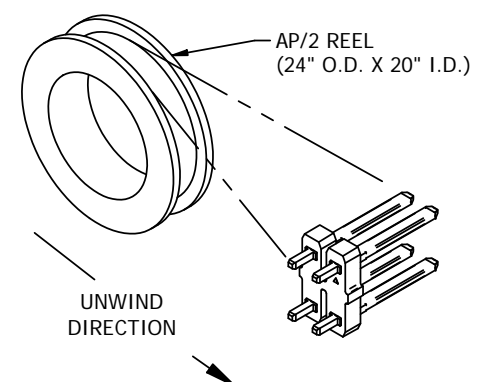
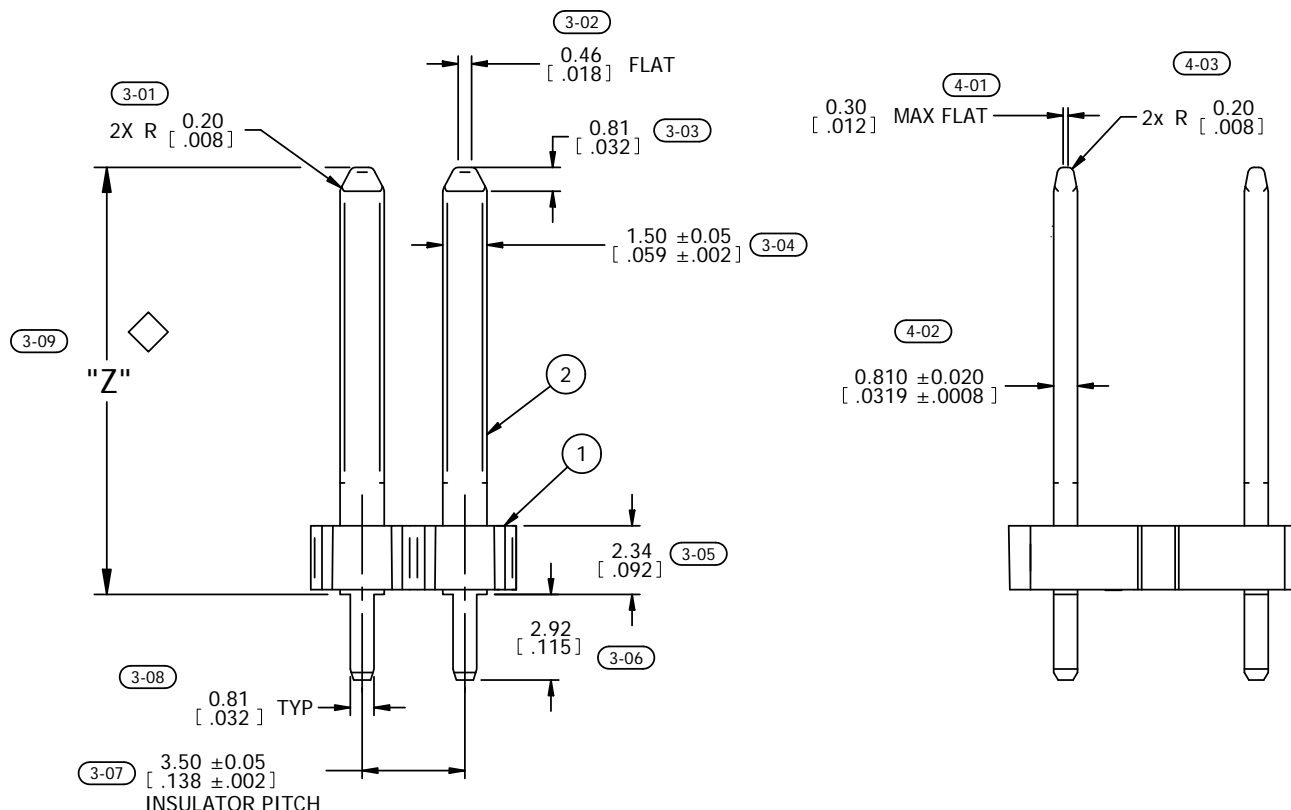
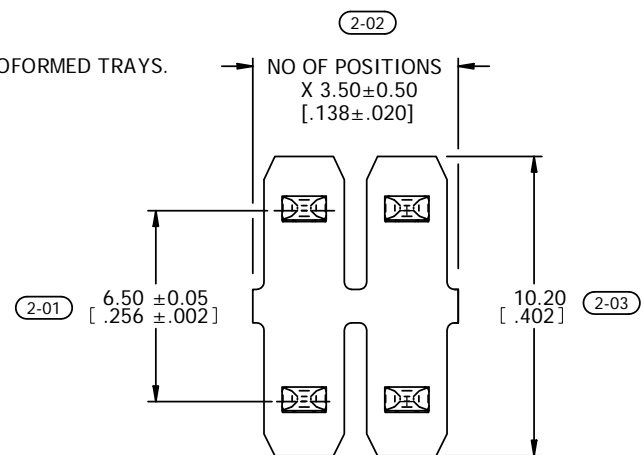

5 REELED HEADER ORIENTATION

**MATERIAL:**

5-01 1 **INSULATOR:**  
GLASS FILLED  
THERMOPLASTIC POLYESTER,  
FLAMMABILITY RATED: UL 94HB  
COLOR: BLACK

5-02 2 **PIN:** BRASS C26000

5-03 **FINISH:**  
SEE PART NO./ORDERING CODE

**CONFIDENTIAL  
CUSTOMER DRAWING**

P/N 23-1078R04A1TT SHOWN

The drawing and the information set forth hereon are the property of Autossplice, Inc. and are to be held in trust and confidence. Publication, disclosure, or use for any purpose not expressly authorizing in writing by Autossplice, Inc. is prohibited.

TOLERANCES UNLESS OTHERWISE SPECIFIED		DIMENSIONS IN [ ] (INCHES)		Autossplice, Inc. 10121 Barnes Canyon Rd. San Diego, CA 92121-2725 RSB-535-0077	
DECIMAL	XX = ±0.3 [XX] = ±[.01]	THIRD ANGLE PROJECTION	DRAWN BY	DATE	
ANGULAR	XXX = ±0.13 [XXX] = ±[.005]		ENGINEERED BY	DATE	
ITEM NUMBERS FOR INSPECTION	XX	TITLE			
DENOTES SPECIAL CHARACTERISTIC		AUTOHEADER, 2 ROW, 3.5mm X 6.5mm			
SIZE	C OAE89	DRAWING NUMBER	C23-1078R [ ] [ ] [ ] [ ] TT	REVISION	
SCALE	10:1	CAD NO.	C23-1078R [ ] [ ] [ ] [ ] TTa.dft	MODEL NO.	23-1078R04A1TT.asm
					SHEET 1 OF 1

4

3

2

1